

Captivate
USB / Bluetooth
Speakerphone



AT-CAP-SP100

Atlona Manuals
Speakerphone

Version Information

Version	Release Date	Notes
1	March 2022	Release

Sales, Marketing, and Customer Support

Main Office

Atlona Incorporated
70 Daggett Drive
San Jose, CA 95134
United States

Office: +1.877.536.3976 (US Toll-free)
Office: +1.408.962.0515 (US/International)

Sales and Customer Service Hours
Monday - Friday: 6:00 a.m. - 4:30 p.m. (PST)

<https://atlona.com/>

International Headquarters

Atlona International AG
Tödistrasse 18
8002 Zürich
Switzerland
Office: +41 43 508 4321

Sales and Customer Service Hours
Monday - Friday: 09:00 - 17:00 (UTC +1)

Operating Notes



IMPORTANT: Visit <https://atlona.com/product/at-cap-sp100> for the latest firmware updates and User Manual.

Warranty



To view the product warranty, use the following link or QR code:

<https://atlona.com/warranty/>.

Important Safety Information

CAUTION
 RISK OF ELECTRIC SHOCK
 DO NOT OPEN

CAUTION: TO REDUCE THE RISK OF
 ELECTRIC SHOCK
 DO NOT OPEN ENCLOSURE OR EXPOSE
 TO RAIN OR MOISTURE.
 NO USER-SERVICEABLE PARTS
 INSIDE REFER SERVICING TO
 QUALIFIED SERVICE PERSONNEL.



The exclamation point within an equilateral triangle is intended to alert the user to the presence of important operating and maintenance instructions in the literature accompanying the product.



The information bubble is intended to alert the user to helpful or optional operational instructions in the literature accompanying the product.

1. Read these instructions.
2. Keep these instructions.
3. Heed all warnings.
4. Follow all instructions.
5. Do not use this product near water.
6. Clean only with a dry cloth.
7. Do not block any ventilation openings. Install in accordance with the manufacturer's instructions.
8. Do not install or place this product near any heat sources such as radiators, heat registers, stoves, or other apparatus (including amplifiers) that produce heat.

9. Do not defeat the safety purpose of a polarized or grounding-type plug. A polarized plug has two blades with one wider than the other. A grounding type plug has two blades and a third grounding prong. The wide blade or the third prong are provided for your safety. If the provided plug does not fit into your outlet, consult an electrician for replacement of the obsolete outlet.
10. Protect the power cord from being walked on or pinched particularly at plugs, convenience receptacles, and the point where they exit from the product.
11. Only use attachments/accessories specified by Atlona.
12. To reduce the risk of electric shock and/or damage to this product, never handle or touch this unit or power cord if your hands are wet or damp. Do not expose this product to rain or moisture.
13. Unplug this product during lightning storms or when unused for long periods of time.
14. Refer all servicing to qualified service personnel. Servicing is required when the product has been damaged in any way, such as power-supply cord or plug is damaged, liquid has been spilled or objects have fallen into the product, the product has been exposed to rain or moisture, does not operate normally, or has been dropped.



Federal Communication Commission Interference Statement

This equipment has been tested and found to comply with the limits for a Class B digital device, pursuant to Part 15 of the FCC Rules. These limits are designed to provide reasonable protection against harmful interference in a residential installation. This equipment generates, uses, and can radiate radio frequency energy and, if not installed and used in accordance with the instructions, may cause harmful interference to radio communications. However, there is no guarantee that interference will not occur in a particular installation. If this equipment does cause harmful interference to radio or television reception, which can be determined by turning the equipment off and on, the user is encouraged to try to correct the interference by one or more of the following measures:

- Reorient or relocate the receiving antenna.
- Increase the separation between the equipment and receiver.
- Connect the equipment into an outlet on a circuit different from that to which the receiver is connected.
- Consult the dealer or an experienced radio/TV technician for help.

Caution: Any changes or modifications not expressly approved by the party responsible for compliance could void the user's authority to operate this equipment.

FCC Caution:

This device complies with Part 15 of the FCC Rules. Operation is subject to the following two conditions: (1) This device may not cause harmful interference, and (2) this device must accept any interference received, including interference that may cause undesired operation.

Radiation Exposure Statement:

The device has been evaluated to meet general RF exposure requirement. The device can be used in portable exposure condition without restriction.

This device complies with Industry Canada licence-exempt RSS standard(s).

Operation is subject to the following two conditions:

- (1) This device may not cause interference, and
- (2) This device must accept any interference, including interference that may cause undesired operation of the device.

L'appareil a été évalué pour répondre aux exigences générales d'exposition aux radiofréquences. L'appareil peut être utilisé en condition d'exposition portable sans restriction.

Le présent appareil est conforme aux CNR d'Industrie Canada applicables aux appareils radio exempts de licence.

L'exploitation est autorisée aux deux conditions suivantes:

- (1) l'appareil ne doit pas produire de brouillage, et
- (2) l'utilisateur de l'appareil doit accepter tout brouillage radioélectrique subi, même si le brouillage est susceptible d'en compromettre le fonctionnement.

Copyright, Trademark, and Registration

© 2021 Atlona Inc. All rights reserved. "Atlona" and the Atlona logo are registered trademarks of Atlona Inc. Pricing, specifications and availability subject to change without notice. Actual products, product images, and online product images may vary from images shown here.

All other trademark(s), copyright(s), and registered technologies mentioned(s) in this document are the properties of their respective owner(s).

Table of Contents

Introduction	6
Features	6
Package Contents	6
Panel Description	7
Installation	8
Mounting Instructions	8
Secure Mounting *sold separately*	8
Connection Instructions	11
Power	11
Compatibility	11
Qi Charging	11
Connection Diagram	12
Cascading	13
Appendix	14
Specifications	14

Introduction

The Atlona Captivate™ AT-CAP-SP100 is a USB / Bluetooth® speakerphone for use with popular video conferencing and unified communications platforms including Zoom™ and Microsoft® Teams. The CAP-SP100 provides microphone and speaker audio in a single elegant enclosure suitable for meeting rooms as well as executive and home office environments. USB, Bluetooth, and analog audio connectivity ensures compatibility with a wide array of computers, laptops, and mobile devices. The CAP-SP100 features a 6-element microphone array for 360-degree voice capture as well as the ability to concentrate audio pickup on individual talkers while suppressing background noises. Sophisticated audio processing optimized for voice intelligibility allows meeting participants to be heard loud and clear. The included battery allows the speakerphone to operate for up to 8 hours without a power connection. The CAP-SP100 speakerphone is an ideal addition to video conferencing system designs that utilize our USB cameras as well as Omega™ Series switching, extension, and video processing solutions.

Features

- USB-C, Bluetooth, and analog audio connectivity for compatibility with a wide array of computers, laptops, and mobile devices.
- Omnidirectional coverage captures voices in up to a 16 foot (5 meter) radius.
- 6-element microphone array focuses audio pickup on individual talkers and suppresses background noises.
- Sophisticated acoustic echo cancellation and noise reduction enhance voice intelligibility by reducing unwanted sounds.
- Bezel buttons provide access to power, volume, microphone mute, answer / hang up, and Bluetooth directly from the device.
- Bezel LEDs display status of audio and battery levels.
- Battery supports 8-hours of operation on a single charge.
- Supports both USB and Qi wireless charging.
- Using Bluetooth and Qi together allows for a fully wireless user experience.
- Elegant design that looks good in conference rooms, executive offices, and home offices.
- Durable metal enclosure.
- Cascade Cable (AT-CAP-SP100-CBL sold separately) allows two CAP-SP100 speakerphones to be connected and work together to cover larger meeting spaces.
- Secure Mount (AT-CAP-SP100-MNT sold separately) option allows the speakerphone to be securely mounted to a flat surface to prevent tampering and theft.

Package Contents

- 1 x AT-CAP-SP100
- 1 x AUX Cable
- 1 x USB-C to USB A Cable
- 1 x Installation Guide

Panel Description

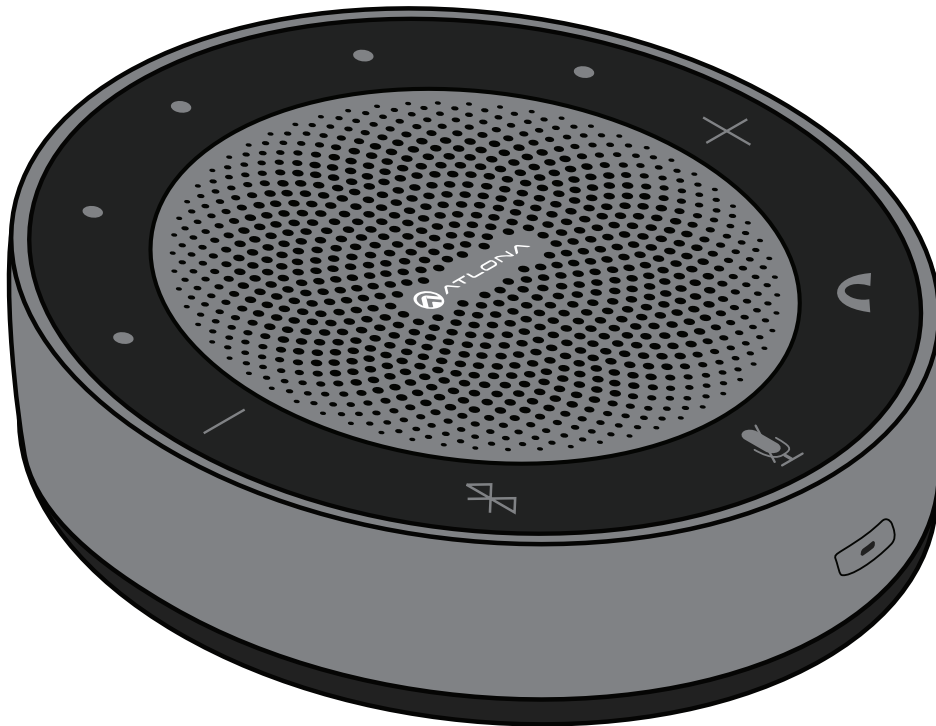

1 Volume / Power Indicators

While the unit is on, the indicators will display the volume level when the volume buttons are pressed. Quickly press the power button to have the LEDs display the power level. LEDs will display green for power.

2 Volume Buttons

Use the plus and minus buttons to increase or decrease the volume level.

3 Answer/Hang up Button

Select this button to accept incoming calls. When in a call press to hang up the call.

i NOTE: Some apps or devices may require the button to be held for up to 5 seconds to hang up.

4 Audio In/Out Port

Connect the included AUX cable from this port to a PC or a second unit for audio chaining (using AT-CAP-SP100-CBL).

5 5V 2A USB-C Port

Connect the included USB-C to USB A cable from this port to either a PC or USB power strip. This port will pass through audio and also be used for power.

6 Bluetooth Button

Press and hold the button for 2 seconds to turn Bluetooth on and off. When Bluetooth is connected (LED will be blue), hold the button until it is disconnected.

7 MIC Mute/Unmute

Press this button to mute and unmute the microphone. The LED will turn red when muted.

8 Power Button

Press and hold the button to turn the unit on and off. The unit will beep when turning on or off. This button can also be quickly pressed to display the power level.

Installation

Mounting Instructions

Secure Mounting *sold separately*

An optional secure mount (AT-CAP-SP100-MNT) can be purchased through atlona.com.

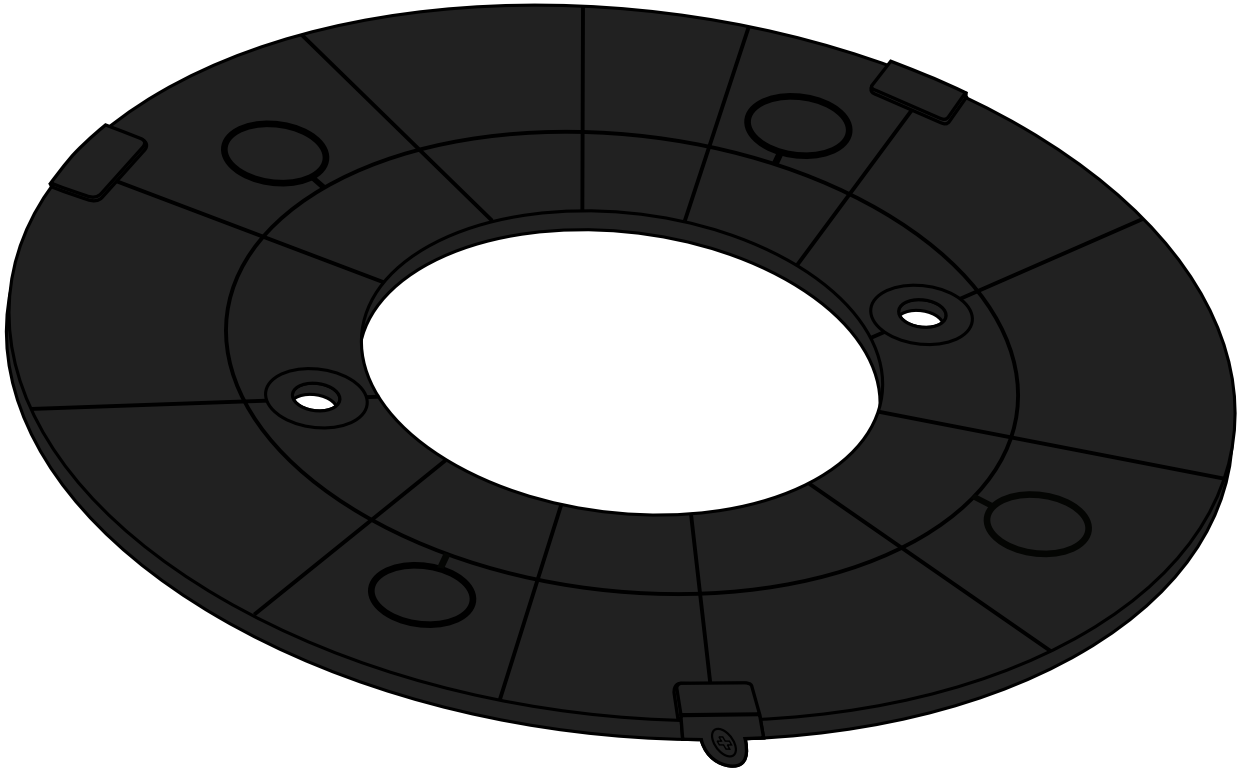

1. Remove the screw and detachable lip from the front of the secure mount.

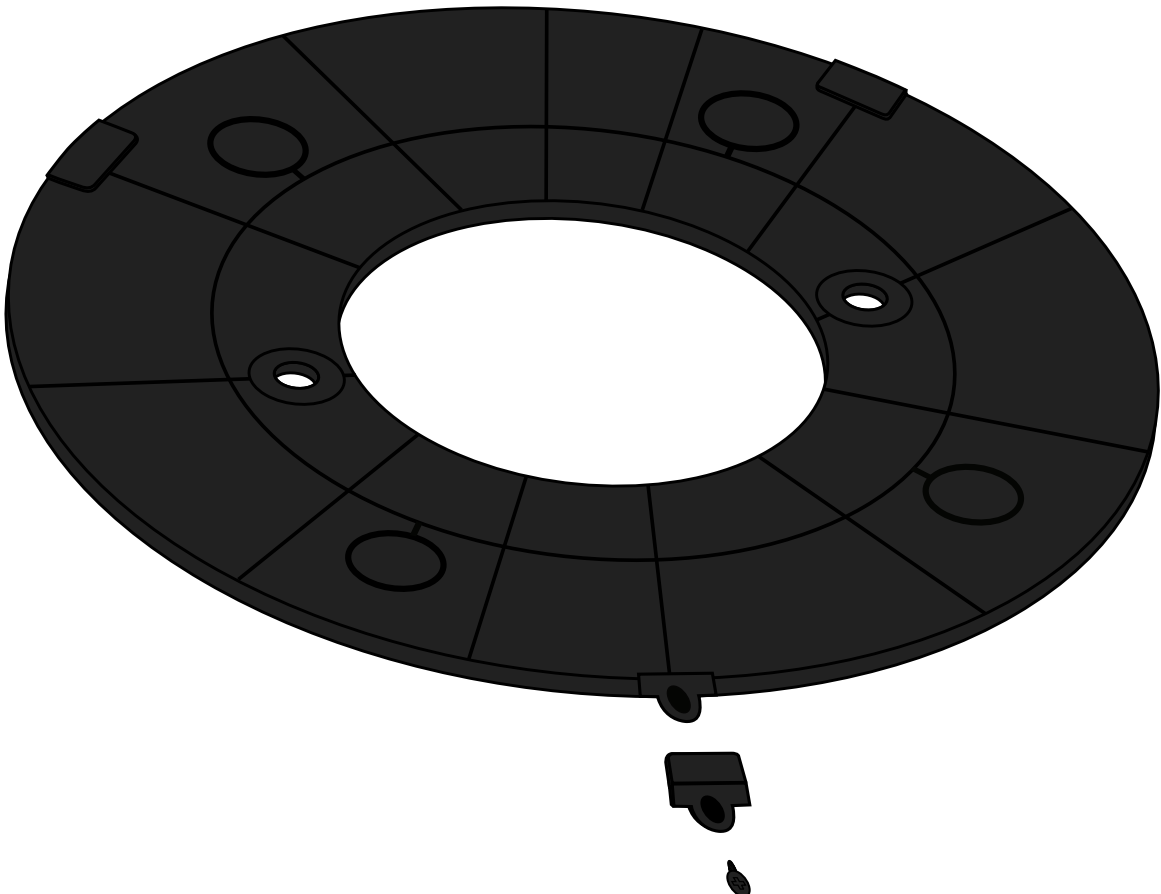

2. Secure the unit to the preferred surface (e.g. table top). There are two options for securing it to the table:
 - a. Run the included two bolts and nuts (included with AT-CAP-SP100-MNT) or two wood screws (not included) through the mount holes and screw them into the table/surface.

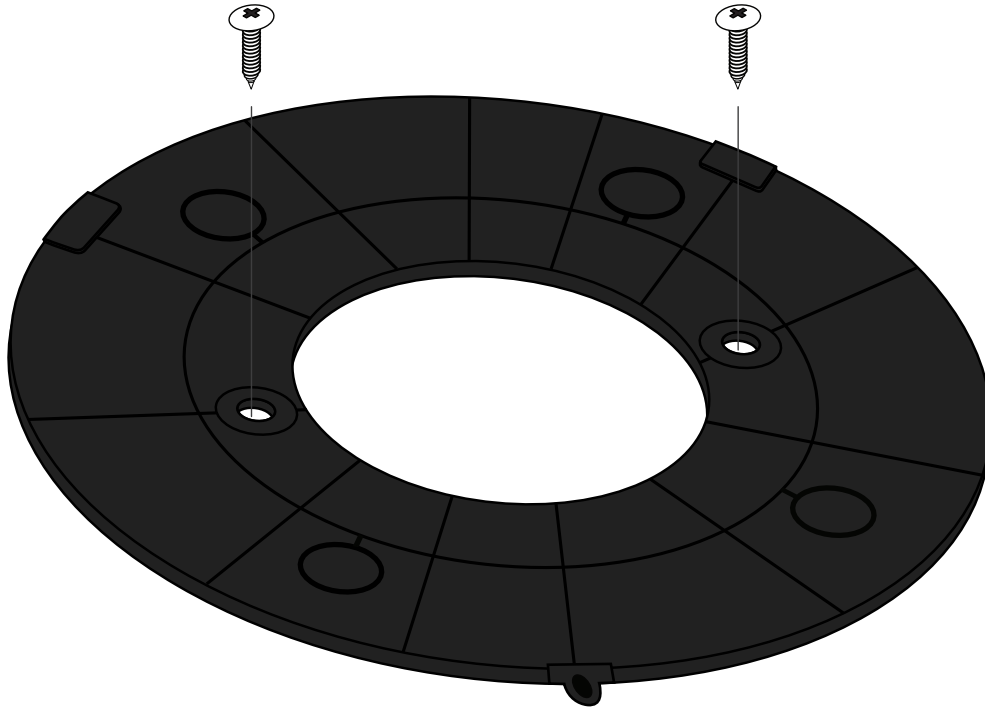

- b. Remove the paper from the top of the included adhesive ring (included with AT-CAP-SP100-MNT) and press it firmly to the bottom of the mount. Once done, remove the paper from the bottom of the adhesive ring and press the secure mount (adhesive side down) onto the table/surface for 15 seconds to ensure the mount is secure.

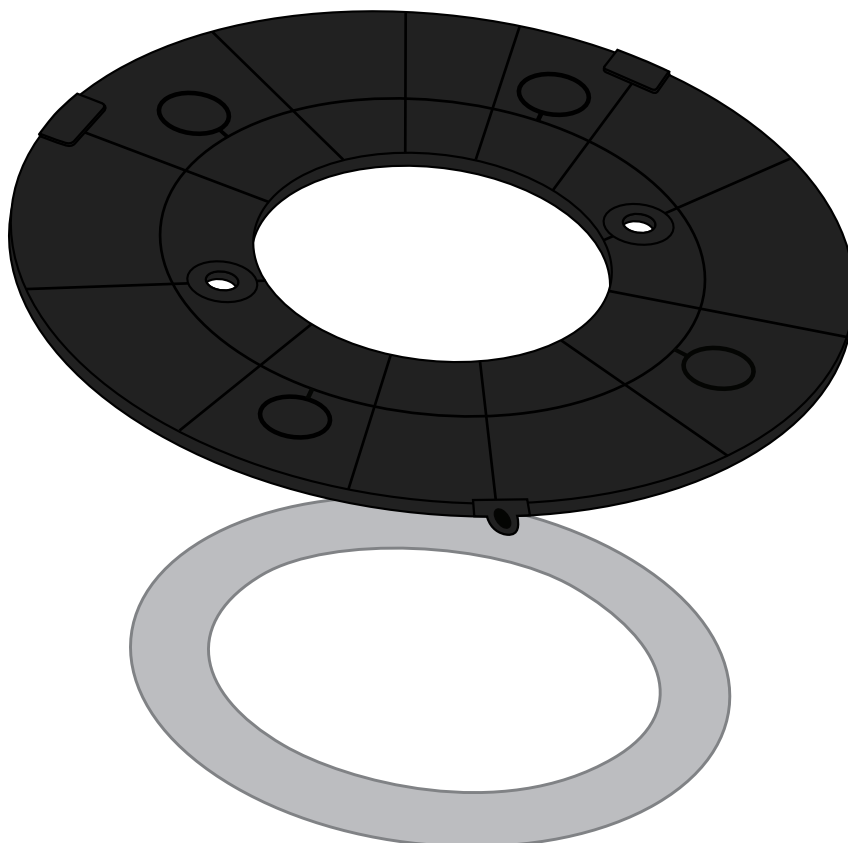

- Slide the AT-CAP-SP100 onto the mount, ensuring the bottom of the unit is under the two lips of the mount.



- Attach the previously removed detachable lip with the screw from the first step. This will secure the unit to the mount.

Connection Instructions

1. Press the power button until the unit turns on. A beep will play to indicate the power has turned on.
2. Connect the unit to the audio conference device (e.g. PC).
 - a. Bluetooth - Bluetooth will start flashing blue when powered on to connect. If connected through USB-C to a computer, the bluetooth button should be pressed and held for 5 seconds to enable pairing. Go to the conference device and select the AT-CAP-SP100 from the Bluetooth device list.
 - b. AUX - Connect the AT-CAP-SP100 to the audio conference device using the included AUX cable. The device should auto detect the speakerphone.
 - c. USB - Connect the AT-CAP-SP100 to the audio conference device using the included USB-C to USB A cable. The device should auto detect the unit.

i NOTE: Mute status sync on Microsoft Teams will only display when the AT-CAP-SP100 is connected via USB.

3. Select the AT-CAP-SP100 as the default audio device for input and playback.

Power

The AT-CAP-SP100 will come with a small power charge. The unit will need to be charged fully before using.

- a. If using the unit with the USB-C to USB A cable, it will charge while in use and nothing additional will be needed.

i NOTE: Certain devices will send data over USB to the AT-CAP-SP100 when powered down, this will cause the unit to power back on.

- b. If using the unit with the AUX cable or over Bluetooth, the device can be powered through the included USB-C to USB A cable or using Qi wireless charging.

Qi Charging

There are many types of Qi chargers. To work with the AT-CAP-SP100, it must provide 7.5W for power. Atlona has tested some chargers to ensure compatibility. See the table below for tested Qi chargers:

Compatible Chargers	
Anker PowerWave II Pad	Apple MagSafe Charger
Anker 313 Wireless Charger Pad	Logitech Power Pad (950-000010)

Compatibility

AT-CAP-SP100 is compatible with any device that uses Bluetooth, USB, or AUX inputs, however, powering capabilities differ per device. The below tables will list the Atlona products that can power the AT-CAP-SP100 without additional power being needed and the ones that will need an additional USB hub or Qi charger to power the AT-CAP-SP100.

Atlona products that do NOT require additional power sources	
AT-OME-MS42	AT-OME-EX-RX
AT-OME-MS52W (front USB ports only)	AT-OME-EX-TX
AT-OME-SR21	AT-OME-EX-KIT
AT-OME-MH21	AT-OME-EX-KIT-LT
AT-OME-PS62	AT-USB-EX100-RX

Atlona products that require additional power sources	
AT-OME-EX-TX-WP-LT	AT-USB-EX100-TX
AT-OMN-324	AT-OME-EX-TX-WP
AT-OME-EX-TX-WPC	AT-OME-EX-TX-WP-E
AT-OME-SW21-TX-WPC	

Connection Diagram

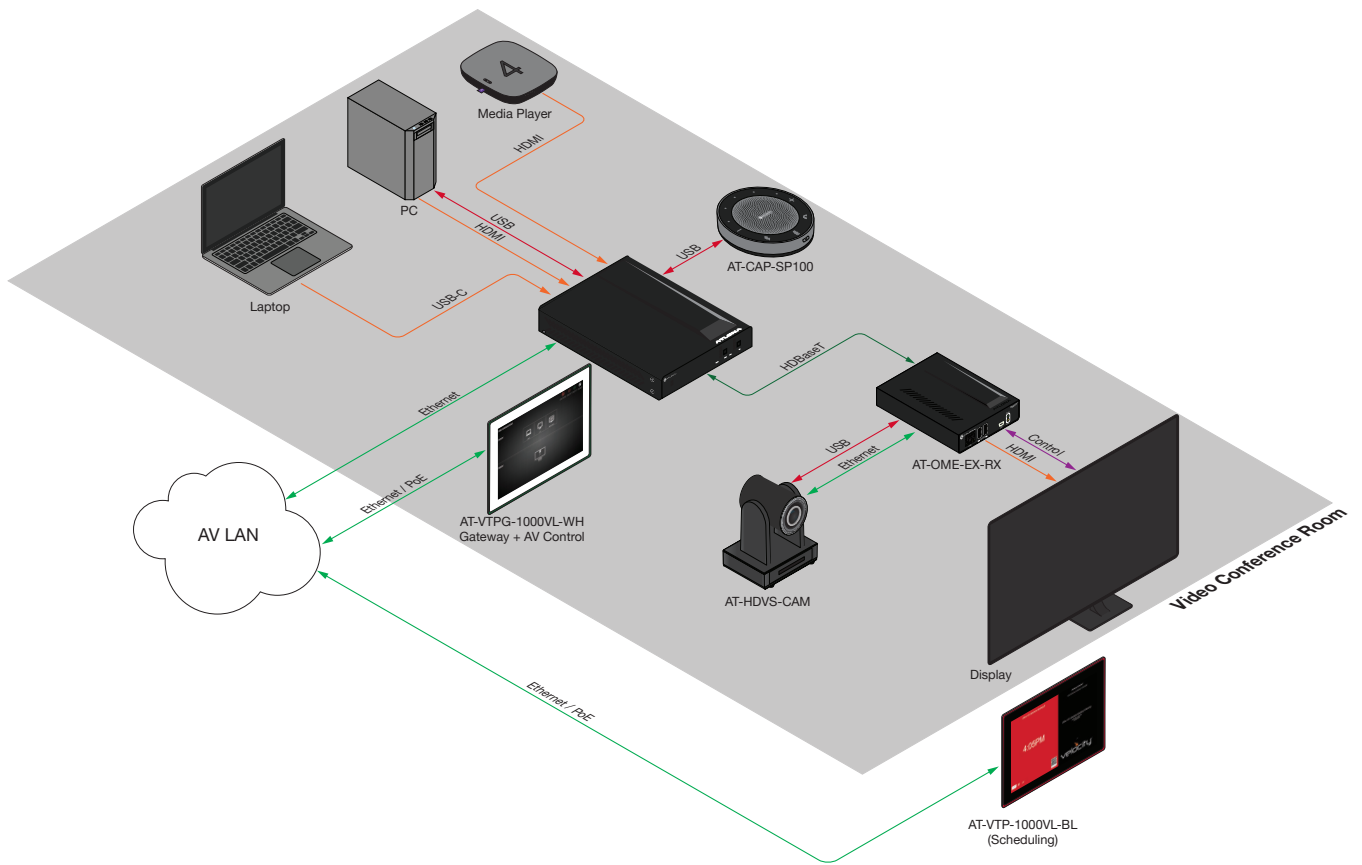

Cascading

A cascade cable (AT-CAP-SP100-CBL) can be purchased through atlona.com to allow two AT-CAP-SP100s to be connected to another, enabling a larger conference area to be covered.

i NOTE: Both units are powered separately. The cascade cable will not pass power between the units.

1. Connect one end of the cascade cable to the AUX port of the first unit and the second end into the AUX of the second unit.

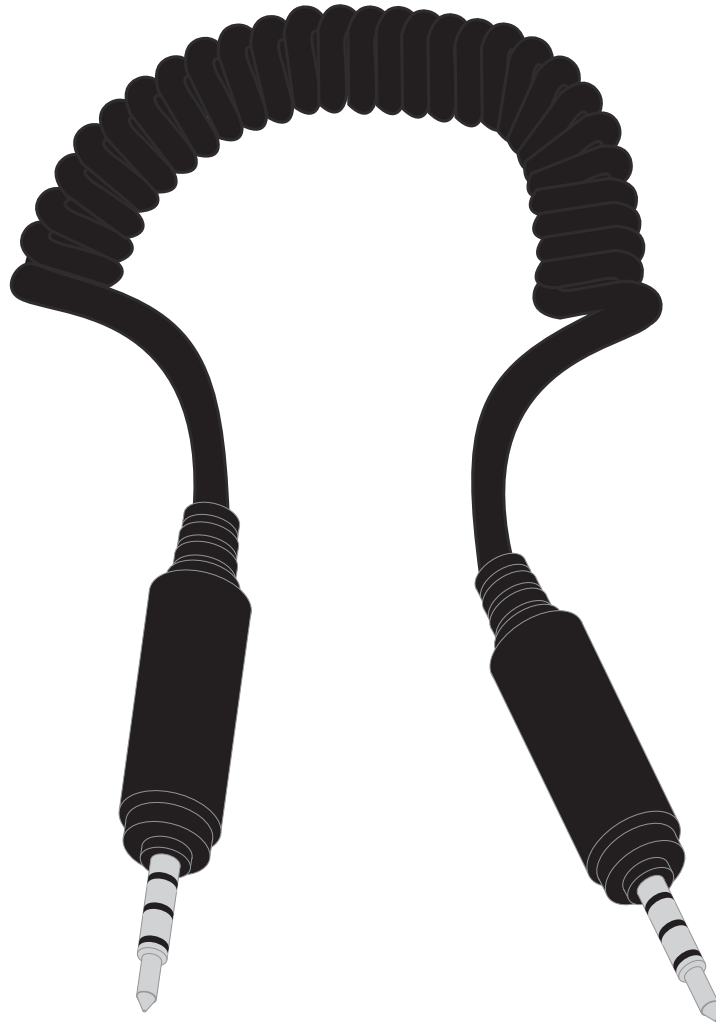

2. Power on the first unit and connect it to the conference device. The connection can be either USB or Bluetooth, but the AUX port will be unavailable while cascading.
3. Select the unit as the default audio device for audio input and playback.
4. Power on the second unit. It will detect the connection to the first unit and pair to share controls.

Now that both units are on and connected, any button presses on either unit will be mirrored on the other unit.

i NOTE: Mute status of the secondary device will not display in Microsoft Teams. The secondary AT-CAP-SP100 will display the correct status light on the unit.

Appendix

Specifications

System Requirements		
Operating System w/USB	Windows 10+, macOS 11+, chromeOS	
Operating System w/Bluetooth	Windows 10+, macOS 11+, iOS 14+, Android 11+	

Conferencing	
Compatibility	All platforms (e.g. Microsoft Teams, Zoom, Skype, FaceTime, etc)
Control Synchronization	Microsoft Teams via USB only

Audio	
Microphone	
Type	6-element microphone array
Pickup	5m radius
Frequency Response	150Hz – 8kHz
Speaker	
Max SPL	80 dB SPL @ 1m
Frequency Response	150Hz – 16kHz
Processing	Acoustic Echo Cancellation, Noise Reduction

USB	
Port	1 x Type C USB
Signal	1 x 2.0
Maximum Data Rate	2.5 Mbps

Bluetooth	
Interface	Wireless
Signal	Bluetooth 4.2

Buttons and Indicators	
Control Buttons:	
Power	1 - momentary, tact-type
Bluetooth, Volume +/-, Answer/Hang up, Mute	5 - momentary, touch
Function Indicators:	
Power Button LED	1 - LED, white/green
Battery/Volume LEDs	5 - LED, white/green
Mute LED	1 - LED, red/white
Bluetooth LED	1 - LED, blue/white

Connectors	
5V 2A USB-C	1 - USB Type-C v2.0, 24-pin female
Audio In/Out	1 - 3.5 mm, unbalanced 2-channel

Temperature	Fahrenheit	Celsius
Operating	23 to 104	-5 to 40
Storage	-4 to 140	-20 to 60
Humidity (RH)	10% to 90%, non-condensing	

Power	
USB	USB-C, 5V 2A
Wireless	Qi (7.5W)
Battery	Lithium Ion, 8 hour use - single charge

Dimensions	Inches	Millimeters
H x D (diameter)	1.39 x 4.73	35.2 x 120

Weight	Pounds	Kilograms
Device	0.87	0.40

Certification	Description
Device	CE, FCC, UKCA, RCM, China RoHS

Compliance	
NDA-899	Yes

Warranty	
Device	2-year limited