

# LEL023 Height Adjustable Ergonomic Lectern

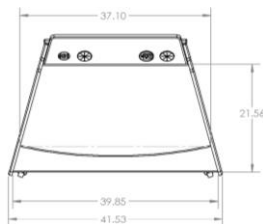
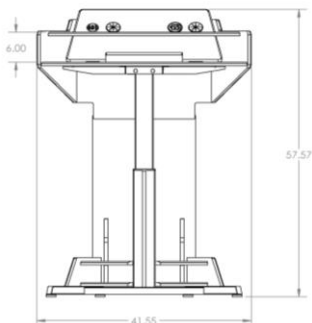
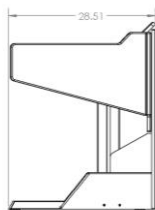
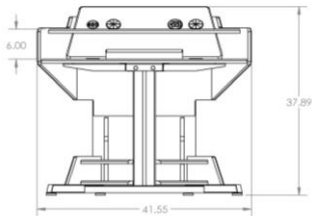

**LEL023** is an electric height adjustable ADA lectern. It was designed with an ergonomic double work surface that provides a little extra space inside to fit slim electronics. The units contemporary and sturdy design is made from scratch resistant thermowrap finished panels. The standard finish consists of 'SGT Shark Grey' on the outer body with your choice of finish on the front panel (customizable on Order Form). This lectern is a wonderful solution for giving public presentations and can be used as a single workstation as well.

## Standard Features

- Electric Height Adjustable Column
- Base Levelers (Replaceable with Casters)
- Wedge With Wireless Qi Compatible Charging
- CUB3 on Wedge Surface
- x2 Cable Grommets on Wedge Surface
- Wire Management Solutions
- Two Level Ergonomic Work Surface
- Modesty Panel
- Highly Resistant Thermowrap Finish
- Ships Assembled

## Options

- **PLM1022** LCD Monitor Mount
- **FM3** Countdown Timer and Clock
- **MIC-18** MX418 S/C Microflex Gooseneck Microphone
- **LIGHT-18** Adjustable Gooseneck Light
- **PB** 6 Outlet 110V Power Bar
- **PC-PATCH** Power Panel with Surge Protection and USB Port
- **CUB3** Round Cable Well
- **CUB4** Round Cable Well
- **CUB22** Black 3 Module Panel
- **CUBM3** 3 Module Power & Data Panel
- **CUBM4** 4 Module Power & Data Panel
- **50CAS** Easy Maneuvering Casters
- **WM2342** 400x400 VESA TV Display Mount
- **C900S** Single Monitor Arm
- **C900D** Dual Monitor Arm
- **WM2342** 400x400 VESA TV Display Mount
- **CUSTOM CUTOUT** Cutouts for Electronics or Other Items

## Specifications

**Model:** LEL023

**Width:** 41.5"

**Depth:** 28.15"

**Height:** 33.8" - 53"

**Finishes:**



Other finishes are available. Check website.

The information contained in this drawing is the sole property of Audio Visual Furniture International. Any reproduction in part or as a whole without the written permission of Audio Visual Furniture International is prohibited. We can build or modify stock configurations to suit customer specifications. Please contact us to discuss how this service can help meet your needs. Some quantity restrictions may apply. Specification subject to change without notice. Computers, cameras, monitors, etc. are shown to illustrate product usage and are not included unless otherwise noted.